

# Vector Tile Server in the Geographic Information System at Bapenda Pekanbaru City

Desy Herlina Citra<sup>1\*</sup>, Muhammad Jazman<sup>1</sup>, Anofrizen<sup>1</sup>, M Afdal<sup>1</sup>, Arief Rahman<sup>2</sup>

<sup>1</sup>Fakultas Sains dan Teknologi, Sistem Informasi, Universitas Islam Negeri Sultan Syarif Kasim, Pekanbaru, Indonesia

<sup>2</sup>Badan Pendapatan Daerah Pekanbaru

Email: <sup>1\*</sup>111950324625@students.uin-suska.ac.id, <sup>2</sup>jazman@uin-suska.ac.id, <sup>3</sup>anofrizen@uin-suska.ac.id, <sup>4</sup>m.afdal@uin-suska.ac.id, <sup>5</sup>ariefrahmandeni@gmail.com

Email Penulis Korespondensi: 111950324625@students.uin-suska.ac.id

**Abstract**—The Regional Revenue Agency (Bapenda) is an organization primarily focused on regional taxation matters. Bapenda City of Pekanbaru used desktop-based WebGIS to view spatial data related to taxes. The users of this system must engage directly with GIS hardware in order to get information about taxes, which is a disadvantage of this system. Furthermore, the WebGIS utilized by Bapenda currently relies on WMS (Web Map Service). However, due to the extensive data processing requirements, WMS is not deemed suitable. WMS may result in broken labels, causing confusion among users, and it also has limitations when it comes to styling capabilities. This study uses a qualitative research methodology with a case study approach. This study's goal is to recommend the use of GIS, specifically the GeoServer and PostGIS programs, for efficient data storage table administration and map digitalization. Gaining access to a spatial data infrastructure that works with Vector Tile Server is considered to be beneficial since it will allow spatial data to be presented and styled without placing a heavy load on the client. This GIS enables easier tax auditing and collection in Pekanbaru City through customizable styling to differentiate between taxpayers and non-payers, which will make these responsibilities easier for Pekanbaru City Bapenda. Vector Tile Server was successfully implemented using PostGIS, PostgreSQL, and GeoServer for the construction of a spatial data infrastructure. Vector tile server demonstrated efficient data storage, faster rendering, and improved user experience, showcasing its potential for various domains with maximum zoom level 19.

**Keywords:** GIS; Vector Tile Server; Taxes; Bapenda; GeoServer

## 1. INTRODUCTION

The evolution of information technology has impacted the utilization of Geographic Information Systems (GIS) in acquiring information. GIS is an instrument or system employed for the input, retrieval, manipulation, analysis, integration, display, and storage of geographical data pertaining to the spatial aspects of Earth, and can serve as an aid in the decision-making process concerning a variety of matters ranging from natural resource planning and management to urban, administrative, and environmental issues [1]. GIS can facilitate the identification and comprehension of specific geographic locations or places. A Geographic Information System (GIS) is a versatile tool for working with georeferenced information, allowing operations such as managing spatial data, analyzing data using spatial and thematic components, and generating various documents such as maps, reports, and plots [2]. The primary function of GIS is decision-making, which involves choosing the best sites for new construction, identifying potential mosquito habitats, and evaluating flood-prone areas to develop efficient prevention strategies, while also acknowledging that GIS represents only a portion of reality due to its inherent limitations [3]. GIS is a system that allows for the visualization and analysis of spatial data [4]. GIS programs are equipped with tools to collect, store and manage data such as vector data (Points, lines) and polygons) or Raster data (permanent areas) [5].

Several companies advanced the development of open source vector tile technology in the 2010s. With the advent of the Mapbox Vector Tile and Mapbox GL Specification updates, the vector tile technologies used by different participants across the most well-known map platforms on the internet have become significantly more unified. 2015 saw the adoption of the Mapbox Vector Tile Specification by Esri. The Open Geospatial Consortium performed a Vector Tile Pilot in 2018 to propose a draft standard to handle tile feature data based on the Tiling Vector Tile Specification. Azure Maps, given to the public by Microsoft in 2018, leverages Mapbox GL[6].

Although vector tiles are an old technology, they are not commonly used in Indonesia. The vector tile format, which is optimized for caching, resizing, and providing map imagery quickly, is the vector data equivalent of raster picture tiles for web mapping [7]. Only the geometric information and attributes needed for map features are contained in vector tiles. As a result, the files are smaller, they load more quickly and effectively, and map loading times are enhanced. The benefit is that it may be stylized on the client, which reduces server load.

Pekanbaru City Regional Revenue Agency (Bapenda) serves as a supporting, implementing component in the financial sector and coordinates administrative responsibilities under the direction of the Agency's Head, who reports to the Mayor through the Regional Secretary and is located beneath him or her. The Land and Building Tax (PBB) is one of the levies that may be paid at Bapenda. The Pekanbaru City Bapenda's issue is that it is challenging for staff to collect the PBB tax. To make it simpler for employees to complete their duties, a map is required to locate the proper location with a tax number. It is challenging for field workers because most personnel use the system from desktop computers. Field personnel require a system that is simple to use, such as using a mobile phone. Moreover, considering the substantial amount of data that needs to be processed, the utilization of vector tiles would be more suitable. Previously, Bapenda employed WMS (Web Map Service). However, one drawback of WMS was that the labels would become fragmented when used with tiles, leading to confusion among users.

Many researchers have created GIS for map mapping. One such study was carried out by Eska in 2018 and involved web-based mapping of motorcycle repair businesses in Kisaran City. The study's finding is that users of motorcycles may more easily locate the workshop in Kisaran City thanks to the GIS [8]. Research on GIS for web-based indihome customer network mapping at the PT Telkom Bandar Lampung branch produced the finding that the delivery of customer data information can be presented in the form of interactive map and table displays, along with an evaluation for the development of ODP (Optic Distribution Point) [9]. GIS research and analysis of Landsat 8 imagery to obtain land suitability maps for agricultural crop species by Munir et al in 2023 [10]. Also research by Lbs in 2020, GIS mapping of the district road network [11]. A study by Buana et al. from 2022 uses the free and open-source Leaflet.JS plugin to display polygon representations of the findings of mapping slum areas [12].

The purpose of implementing the Geographic Information System with the Vector Tile Server is to simplify tax auditing and collection for Bapenda. It allows processing of large data volumes, reduces server load by shifting it to the client, and enables faster and more effective file and map loading. Additionally, it provides the ability to style and differentiate individuals based on their tax payment status.

## 2. RESEARCH METHODOLOGY

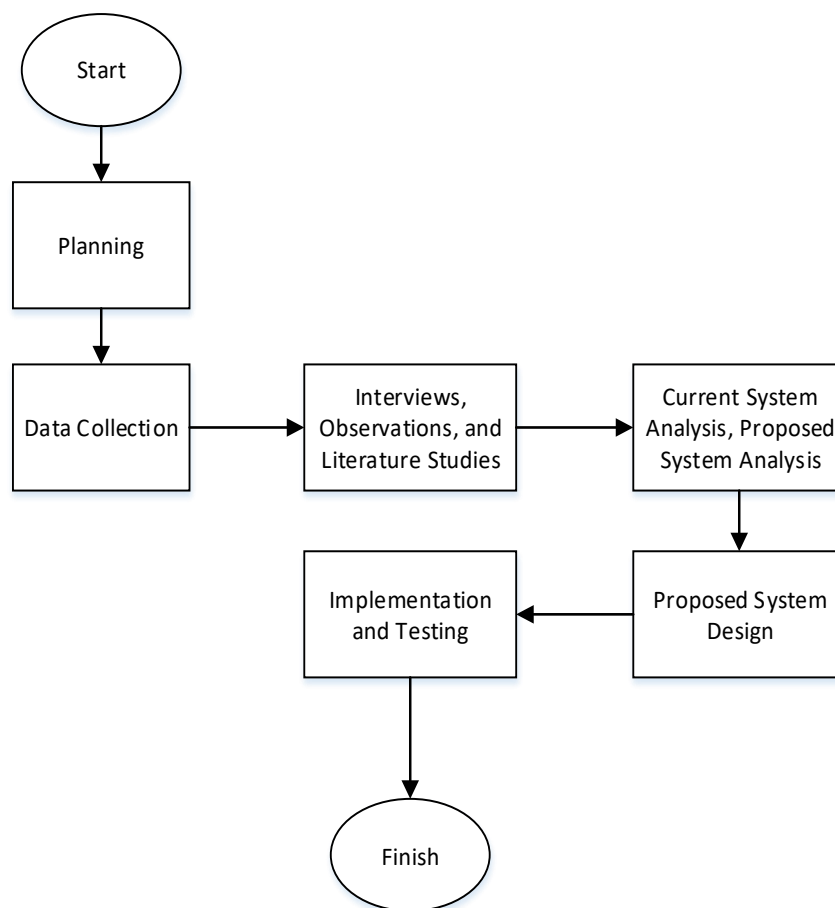

**Figure 1.** Research methodology

This study utilizes a qualitative research methodology with a case study approach to investigate the implementation and effectiveness of a vector tile server in the realm of geospatial data management and visualization. Figure 1 presents a step-by-step illustration of how the research was conducted. It illustrates the research process, which initiates with the planning stage where the research topic is identified, research objectives are formulated, and a literature review is conducted. Subsequently, the data collection phase is undertaken through interviews, observations, and literature review. Following data collection, the analysis phase commences, involving an examination of the existing system at Pekanbaru City Bapenda as well as the proposed system. Upon completion of the analysis phase, the system design stage is initiated, leading to the final step of implementation, encompassing coding and design activities.

### 2.1 Research Location

The research location is in the capital of Riau Province, namely Pekanbaru City. Pekanbaru City is one of 6 regencies/cities in Riau province. Pekanbaru City is located between 101°14' - 101°34' East Longitude and 0°25' - 0°45' North Latitude.

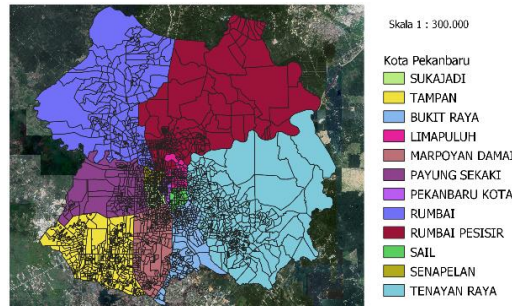

Figure 2. Research location

Pekanbaru City has an area of 632.26 km<sup>2</sup> which is divided into 12 districts, 58 sub-districts as shown in Figure 2.

2.2 GeoServer

The GeoServer is a server written in the Java programming language that facilitates the visualization and manipulation of geospatial data in accordance with the specifications laid out by the Open Geospatial Consortium (OGC). As a result, it affords users with a simple and flexible framework for creating and sharing cartographic representations [10].

2.3 Slippy Map Tilenames

The standard calculation rules are applied for a specific zoom level, usually with zoom level 18 serving as the upper limit, although some tile servers may go beyond this limit [13] shown in table 1.

Table 1. Zoom level

Zoom Level	Tile Coverage	Number of Tiles	Tile Size in Degrees
0	1 tile covers whole world	1 tile	360° x 170.1022°
1	2 x 2 tiles	4 tiles	180° x 85.0511°
2	4 x 4 tiles	16 tiles	90° x [variable]
n	2 <sup>n</sup> x 2 <sup>n</sup> tiles	22 <sup>n</sup> tiles	360/2 <sup>n</sup> ° x [variable]
12	4096 x 4096 tiles	16 777 216	0.0879° x [variable]
16		2 <sup>32</sup> ≈ 4 295 million tiles	
17		17.2 billion tiles	
18		68.7 billion tiles	
19	Maximum zoom for Mapnik layer	274.9 billion tiles	

Equation (1) is an example of writing an equation to find the x coordinate plot for a given longitude and zoom level [13].

$$x = \left[ \frac{lon+180}{360} \cdot 2^z \right] \tag{1}$$

Equation (2) is an example of writing an equation to find the y coordinate plot for a given latitude and zoom level [13].

$$y = \left[ \left( 1 - \frac{\ln\left(\tan\left(\text{lat} \cdot \frac{\pi}{180}\right) + \frac{1}{\cos\left(\text{lat} \cdot \frac{\pi}{180}\right)}\right)}{\pi} \right) \cdot 2^{z-1} \right] \tag{2}$$

Equation (3) is an example of writing an equation to find longitude if we know the x coordinate of the tile and what zoom level it is at [13].

$$lon = \frac{x}{2^z} \cdot 360 - 180 \tag{3}$$

Equation (4) is an example of writing an equation to find latitude if we know the y coordinate of the tile and what zoom level it is at [13].

$$lat = \arctan\left(\sinh\left(\pi - \frac{y}{2^z} \cdot 2\pi\right)\right) \cdot \frac{180}{\pi} \tag{4}$$

2.4 Vector Tile

Vector Tiles are a technology and basemap schema that offer distinct advantages and functionalities compared to raster tiles, particularly with regards to interactivity. Similar to raster tile maps, vector tile maps are also divided into small parts referred to as "tiles," which are then transmitted to the client side based on the requested geographic region [14].

### 2.5 LeafletJs

LeafletJS is an open source JavaScript library that provides a convenient way to facilitate the creation of maps. JavaScript affords a function for presenting maps on web pages, which can be utilized on desktop and mobile browsers alike [15], thereby enabling users to conveniently access maps from anywhere [16]. Leaflets offer a variety of capabilities, including marking features, pop-up, zooms, overlay lines, pans, and shapes [16]. The functionality of Leaflet can be augmented and expanded through the use of plugins, which are designed to enhance usability and optimize performance [17].

## 3. RESULT AND DISCUSSION

### 3.1 Current System Analysis

An analysis of the current system flow is conducted to understand the processing of the geographical information system at Bapenda. The specific process is illustrated in Figure 3.

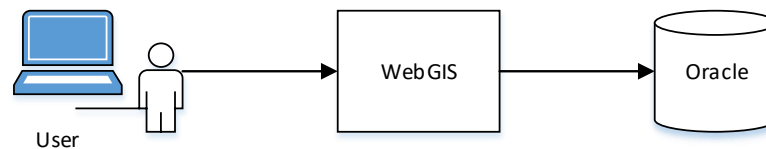
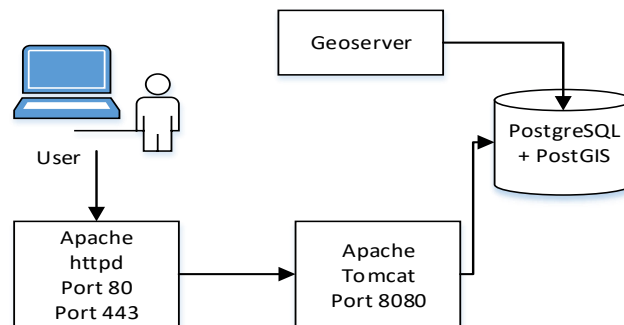

**Figure 3.** Current System Analysis

Figure 3 illustrates that users access WebGIS and interact with Oracle databases. The WebGIS utilizes WMS, allowing users to view the map only when directly connected to a desktop computer.

### 3.2 Proposed System Analysis

The utilization of a Vector Tile Server in the Geographic Information System at Bapenda enables the interactive presentation of tax mapping in the City of Pekanbaru.

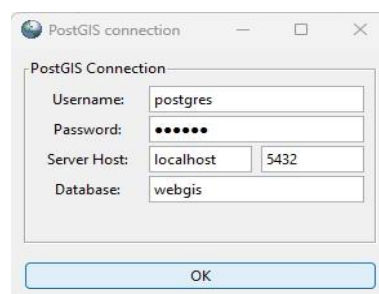

**Figure 4.** Proposed System Analysis

Figure 4 illustrates the research begins with users accessing Apache servers via port 80 or port 443 using secure encryption. From there, the users are directed to Apache Tomcat, which is configured on port 8080 and connected to GeoServer, which uses databases from PostgreSQL and PostGIS. To enhance security, Mod\_Proxy is utilized, which can be configured to filter incoming requests, while also providing the capability to consolidate multiple backend servers into a single server, reducing hardware and maintenance expenses. Also, mod\_rewrite is utilized to build user- and search engine-friendly URLs, which makes them neater and shorter.

### 3.3 Implementation and Testing

#### 3.3.1 PostGIS



**Figure 5.** PostGIS connection

Figure 4 depicts the PostGIS connection as it is filled out with the help of the PostGIS connection with pgAdmin4. PostgreSQL uses pgAdmin4 as a tool for database management. The Log Window will display a successful PostGIS connection. As seen in Figure 4, the PostGIS Log.

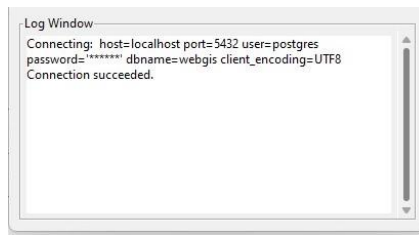

Figure 5. PostGIS connection successful

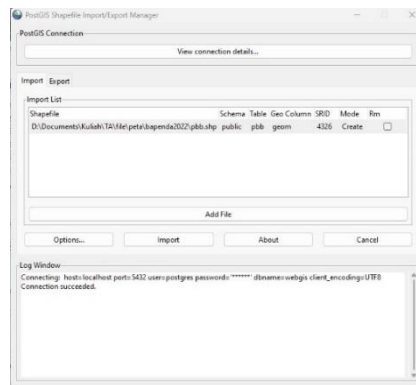

Figure 6. PostGIS Shapefile Import

Figure 5 and 6 shows the PostGIS import of the shp file. Data on Land and Building Tax in the City of Pekanbaru are contained in this SHP file, which was received from the Pekanbaru City Bapenda. Complete the number 4326 in the Spatial Reference Identifier (SRID) column.

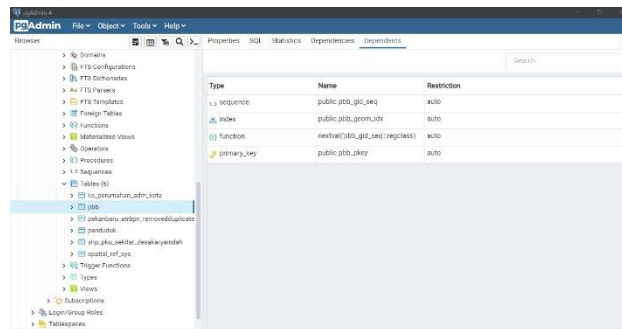

Figure 7. pgAdmin4

After adding the shp file to PostGIS successfully, the data will be sent immediately to pgAdmin4, as seen in Figure 6.

### 3.3.2 GeoServer

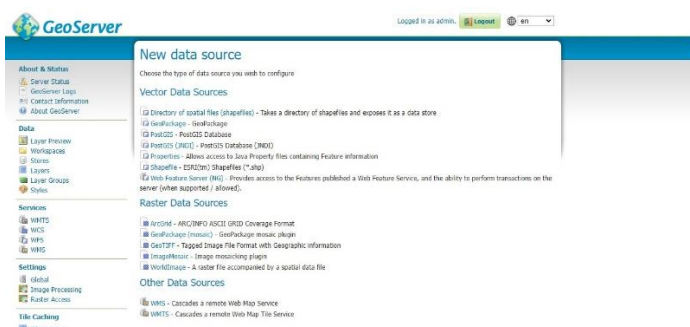

Figure 7. Added data stores

Figure 7 displays the list of Data Stores that may be filled with spatial data in vector format and one of those data stores is the PostGIS database.

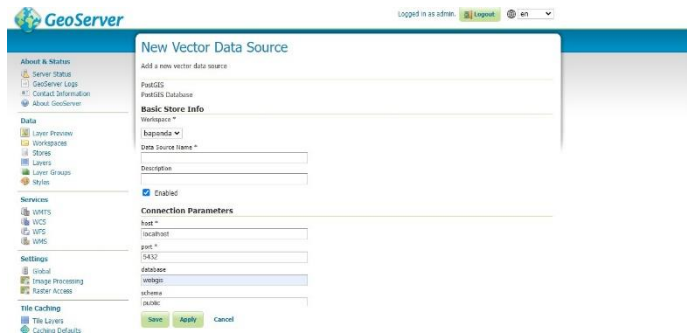

Figure 8. Connect Geoserver and PostGIS

It is important to modify the connection parameters in Figure 8 in order to link PostGIS and GeoServer.



Figure 9. Added a new layer

The interface for creating a new layer is shown in Figure 9. When data is uploaded to PostGIS, it is immediately visible and can be chosen to be published to GeoServer.

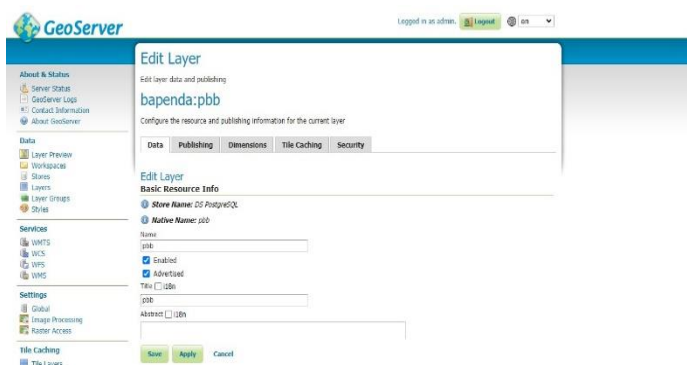

Figure 10. Added pbb layer

The process of adding a new layer is shown in Figure 10. It is crucial to identify the coordinate reference systems in this menu, as shown in Figure 11.



Figure 11. Sets coordinate reference systems

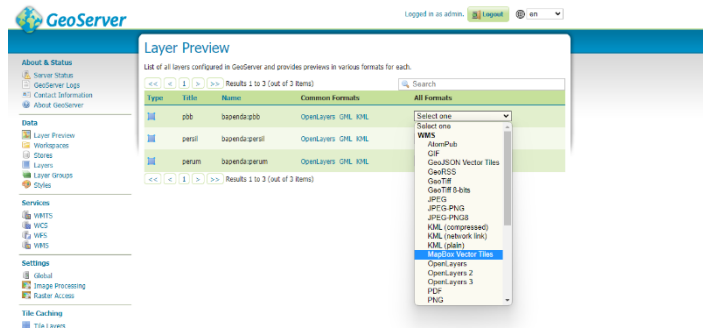

Figure 12. Layer preview

The newly added Layer is shown in Figure 12, and you may select a format to view the Layer in. Figure 13 displays Layer pbb in OpenLayers format.

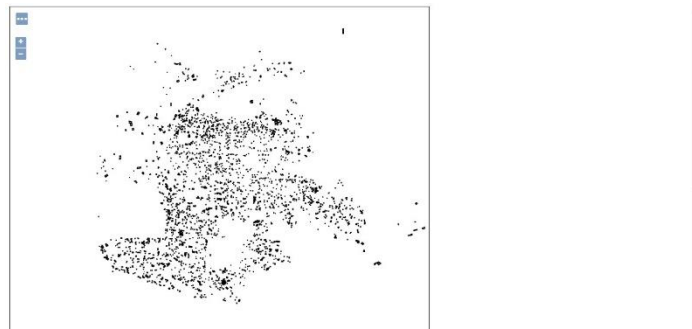

Figure 13. Layers viewed with OpenLayers

### 3.3.3 Tile Server



Figure 14. Tile server

Figure 14 shows an image of Pekanbaru City using a Tile Server located at zoom level 13 with  $x = 204875 - 204879$  and  $y = 130732 - 130734$ . The max zoom level in this tile server is 19.

### 3.3.4 Vector Tile Server



Figure 15. Vector tile server

Figure 15 shows an image of Pekanbaru City using a Vector Tile Server located at zoom level 15 with  $x = 25609 - 25614$  and  $y = 16341 - 16343$  with a white box in the form of data consisting of 26 PBB data attributes. The max zoom level in this vector tile server is 19.

Figure 16. Attribute data PBB

In Figure 16, the tax data attributes include: NOP (Tax Object Number), layer, billing, nama (name), alamat\_wp (taxpayer address), RT (residential unit number), RW (residential group number), kelurahan (village), kecamatan (district), kabupaten (regency), kodepos (postal code), letak\_obj (object location), shm (land certificate), luas\_tanah (land area), njoptanah (land tax assessment), luas\_bgn (building area), njopbgn (building tax assessment), totnjopbb (total tax assessment), transaksi (transaction), bayar (payment), kurang (shortage), denda (fine), totalbayar (total payment), jentransk (transaction type), ket (remarks), and status.

Figure 17. Attribute data

In Figure 17, there are a total of 340,349 data entries. This dataset includes information on various attributes such as penggunaan (land use), persilpa (parcel area), sumbergeom (geometric source), tahun (year), tipehak (land ownership type), tipeproduk (product type), validator, wilayahhid (region ID), FID, layer, and path.

### 3.4 Discussion

In order to ease comparisons with earlier studies and serve as the foundation for validation for progress, it is essential to collect multiple reference sources and supporting data during the course of this research. The following are the relevant references from previous research:

Prior research by Hasibuan and Jazman concentrated on the creation of a Tile Server at UIN Suska Riau. In the study, Google Maps was used as the client application, Mapserver as the server component, and QGIS for map digitization. The tile's design complied with Slippy Map Tilenames' general guidelines. To achieve more accuracy in the produced findings, the analysis and calculation of building and land areas will be carried out in accordance with the calculations in QGIS. While QGIS will offer a Map Grid for reference, Slippy Map Tilenames will also be used to determine the coordinates. [18].

After that, Abdillah, Nawangnugraeni, and Yuniarto carried out a following study with the aim of using LeafletJS to map greenpark. The online-based and open-source nature of LeafletJS was taken advantage of in this study, enabling dynamic and adaptable development. According to the data, there are 19.61% of greenpark in total, which is almost as much as is required for public greenpark in the area [16].

Aini and Pribadi conducted a research project aiming to develop an online promotional media using WebGIS. Open Street Map and Leaflet JS were used as the foundation map while creating the WebGIS. In the course of development, LeafletJS, Codeigniter 3, and the PHP language support framework were all used. The study's output was a WebGIS platform for microbusinesses in Ngunjuk Regency, which included 48 of the 250 microbusinesses spread across 16 subdistricts. The high percentage of 85% that were rated as "very feasible" in the feasibility test showed that the WebGIS platform had been successfully implemented [17].

Based on the descriptions of several previous studies, tile servers and LeafletJs have been utilized for mapping various types of geospatial data. In tile servers, data is typically generated as raster, which limits the ability to apply custom styling. Instead, vector tiles are used in this study, providing more flexible style possibilities. Using vector tiles allows for client-side styling, which reduces the processing load on the server. This approach enables the customization of map styles to meet specific requirements without impacting server performance. This research will employ a vector tile server using GeoServer, integrated with a PostgreSQL database enhanced with PostGIS for spatial data management.

It will also utilize LeafletJS as a web mapping framework to visualize and interact with vector tiles in a user-friendly manner.

## 4. CONCLUSION

Based on research results, Vector Tile Server was successfully implemented in the construction of a spatial data infrastructure. The implementation and testing of a vector tile server using PostGIS, PostgreSQL, and GeoServer is successful. The process involved establishing a database in PgAdmin4, connecting it with PostGIS and PostgreSQL, and configuring GeoServer to generate layers for the vector tile server. By leveraging this technology stack, we created a tile server capable of serving vector tiles optimized for geospatial data rendering at a maximum zoom level of 19. The utilization of a vector tile server offers numerous advantages, including efficient data storage, faster rendering, and improved user experience. The results demonstrate the feasibility and effectiveness of this approach, highlighting the potential for further exploration and application in various domains, such as urban planning, transportation, and environmental monitoring. Overall, the vector tile server built upon PostGIS, PostgreSQL, and GeoServer proves to be a powerful solution for serving optimized and interactive geospatial data through vector tiles, paving the way for enhanced geospatial applications. Future research endeavors could focus on advancing techniques for representing urban environments, such as the development of detailed cityscapes that include multi-floor buildings. Furthermore, the integration of 3D animations through technologies like WebGL offers the potential to enhance the visual experience and interactivity of maps.

## REFERENCES

- [1] B. S. Sulastio, H. Anggono, and A. D. Putra, "Sistem Informasi Geografis Untuk Menentukan Lokasi Rawan Macet Di Jam Kerja Pada Kota Bandar Lampung Pada Berbasis Android," *J. Teknol. dan Sist. Inf.*, vol. 2, no. 1, pp. 104–111, 2021, [Online]. Available: <http://jim.teknokrat.ac.id/index.php/JTISI>.
- [2] V. Olaya, *Introduction to GIS*. 2018.
- [3] O. Huisman and R. A. de By, *Principles of Geographic Information Systems*. 2009.
- [4] C. Nadia, H. Dorthy Ellyany Sinaga, P. Studi Sistem Informasi, and S. Tinggi Managemen Informatika dan Komputer Royal Kisaran, "Implementation Geographic Information Systems in UMKM Mapping in the Batu Batu Regency," vol. 3, no. 4, pp. 969–974, 2022, [Online]. Available: <https://doi.org/10.20884/1.jutif.2022.3.4.201>.
- [5] O. R. Kamariddinovich, K. K. Rakhimjonovna, and M. D. B. Qizi, "Improving Methods For Mapping Irrigation Networks Using GIS Technologies," *Int. J. Educ. Soc. Sci. Humanit. Finl. Acad. Res. Sci. Publ.*, vol. 11, no. 4, pp. 691–699, 2023.
- [6] H. Fujimura *et al.*, "Design and Development Of The UN Vector Tile Toolkit," *Int. Arch. Photogramm. Remote Sens. Spat. Inf. Sci.*, vol. XLII-4/W14, pp. 57–62, 2019, [Online]. Available: <https://doi.org/10.5194/isprs-archives-XLII-4-W14-57-2019>.
- [7] Mapbox, "Vector tiles introduction." <https://docs.mapbox.com/data/tilesets/guides/vector-tiles-introduction/>.
- [8] J. Eska, "Geographic Information System Pemetaan Bengkel Sepeda Motor Di Kota Kisaran Berbasis Web," *J. Sci. Soc. Res.*, vol. I, no. 2, pp. 97–102, 2018.
- [9] A. Rahardi, R. R. N. Fikri, and A. Sudirman, "Sistem Informasi Geografis (SIG) Untuk Pemetaan Jaringan Pelanggan Indihome Berbasis Web DI PT. Telkom Cabang Bandar Lampung," *J. SIMADA (Sistem Inf. dan Manaj. Basis Data)*, vol. 5, no. 1, pp. 14–22, 2022.
- [10] A. Q. Munir, I. Listiawan, E. L. Utari, and M. R. W. Solihin, "Geographic Information Systems for Agricultural Suitable Land At Kabupaten Sleman," ... *Tek. Inform. (Jutif ...)*, vol. 4, no. 1, pp. 97–105, 2023, [Online]. Available: <http://jutif.if.unsoed.ac.id/index.php/jurnal/article/view/759>.
- [11] I. I. Lbs, "Sistem Informasi Geografi Pemetaan Jaringan Jalan Kabupaten Pada Dinas Pekerjaan Umum Bina Marga Kabupaten Mandailing Natal," UIN Suska Riau, 2020.
- [12] D. S. Buana, R. P. Sari, and S. Rahmayuda, "Sistem Informasi Geografis Pemetaan Kawasan Permukiman Kumuh Kota Pontianak Berbasis Website," *J. Sist. Komput. dan Inform.*, vol. 3, no. 4, pp. 384–392, 2022, doi: 10.30865/json.v3i4.4206.
- [13] OpenStreetMap Wiki, "Slippy map tilenames." [https://wiki.openstreetmap.org/wiki/Slippy\\_map\\_tilenames](https://wiki.openstreetmap.org/wiki/Slippy_map_tilenames).
- [14] W. Hu, L. Li, C. Wu, H. Zhang, and H. Zhu, "A Parallel Method For Accelerating Visualization And Interactivity For Vector Tiles," *PLoS One*, vol. 14, no. 8, pp. 1–21, 2019, doi: 10.1371/journal.pone.0221075.
- [15] Mardalius, F. Dristyana, and A. Syafnur, "Sistem Informasi Geografis Penyebaran Covid-19 Di Kabupaten Asahan Menggunakan Framework Codeigniter 4," *J. Sci. Soc. Res.*, vol. 4, no. 3, p. 347, 2021, doi: 10.54314/jssr.v4i3.714.
- [16] M. Z. Abdillah, D. A. Nawangnugraeni, and A. H. P. Yuniarto, "Geographic Information System (GIS) For Mapping Greenpark Using Leaflet JS," *J. Tek. Inform. Kaputama*, vol. 5, no. 2, pp. 259–266, 2021.
- [17] N. K. Aini and C. B. Pribadi, "WebGIS Berbasis Leaflet JS untuk Pemetaan Persebaran Usaha Mikro di Kabupaten Nganjuk," *J. Tek. ITS*, vol. 10, no. 2, pp. 510–515, 2021, doi: 10.12962/j23373539.v10i2.81054.
- [18] A. P. Hasibuan and M. Jazman, "Rancang Bangun Tile Server (Studi Kasus: UIN Suska Riau)," in *Seminar Nasional Teknologi Informasi, Komunikasi dan Industri (SNTIKI) 9*, 2017, pp. 160–169.